

BELT FASTENERS



BSK OVERSEAS INC.

All Kinds Of Belts Fasteners



STEEL BELT LACING



Oval BELT FASTENERS



BELT PUNCHES



Elevator Buckets



CONVEYOR BELT FASTENERS



Grease Cups



BSK OVERSEAS INC is one of the leading Exporters of Belt Fasteners Products throughout the world with the magnificent quality at economical prices according to the customer requirements. Our aim is to maintain uncompromising control on quality by following norms of the standards during production process to produce upgraded Products with the latest technology. Moreover, our quality assurance department issue a unique identity number for its certification.

Further our overseas offices are situated in **USA** and **Canada** working independently for prompt support and supply to the customer.

A brief brochure presents BSK portfolio of Belt Fasteners Products for your ready reference & to generate inquiry.

For more information/range of our products, please contact us:- info@bskoverseas.com

BSK Marketing Division



India (Head Office)

104-A, Lane 4, Sant Avenue, G.T. Road, Amritsar-143001(PB), India

Phone: +91-84370-02153, +91-98149-77533

Email: info@bskoverseas.com



Canada

753 East 51st avenue, Vancouver, BC V5X1E2

Phone: +1(236)996-3000

Email: canada@bskoverseas.com



Usa

121-14, 149 Avenue South Ozone Park ,New York, NY 11420.

Phone: +1(646)595-8096

Email: usa@bskoverseas.com

CONVEYOR BELT FASTENERS

We are Exporter and supplier of complete range of Conveyor Belt Fasteners Plate Hawk Jackson Type.

Markets as per **IS:10288:1982** for Joining rubber conveyor belts used in Mining, Cement, Steel, Thermal, Chemical Plants, Queries Road Constructions, Stone Crushing, Food, Sand & Gravels etc.

Hawk Clip Size

We Offer solid plate Conveyor Belt Fasteners in following Sizes **No. 1, No. 1.5, No. 2, No. 2.5 & No. 3**

Technical Specifications

Material :- The plates and retaining clip are manufactured from cold rolled carbon steel or strip conforming to grade D of **IS : 513-1973** Specification for cold rolled carbon Steel sheet (second revision) `01` Grade D of **IS : 4030-1973**. Specification for cold rolled carbon steel sheet strip for general engineering purposes. These are Zinc Plated for longer life and rust preventions. Specially formed teeth penetrates belt carcass without damaging conveyor belts fiber.

Screw and Nut :- The screw and nut are manufactured from 4.6 of **IS : 1367 (part 3)-1979** "Technical supply conditions for threaded steel fasteners : Part 3 mechanical properties and test methods for bolt, screws and studs with full load ability. These are painted auto black finish for longer life.

Technical Specifications :

Our Conveyor belt Fasteners ensures maximizing conveyors uptime, conveyor safety and belting productivity in a way of longer life on higher tension belt with mechanical fastener rating up to 350 KN/M (=2,000 P.I.W.)

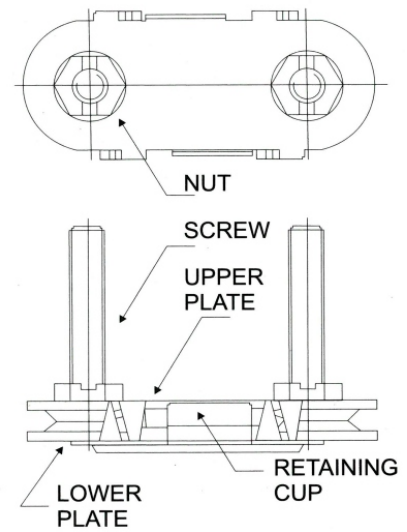

Selection Chart

Fasteners Designation	Belt Thickness in min.	Minimum Pulley Dia in min.	Number of Sets Required for Various Width In mm of Belting											
			6	8	10	13	15	16	20	25	30	40	50	60
No.1	4 to 10	300	6	8	10	13	15	16	20	25	30	40	50	60
No.1.5	9.5 to 17.5	450	-	-	8	10	12	13	16	20	24	32	40	48
No.2	12.5 to 20.5	750	-	-	-	9	10	11	14	17	21	28	35	42
No.2.5	17.5 to 25.5	1050	-	-	-	-	9	10	13	16	19	26	32	39
No.3	20.5 to 30	1250	-	-	-	-	-	10	13	16	19	26	32	39

OVAL BELT FASTENERS

These are used in Lap & Saddle Back Joining These Fasteners are manufactured in Mild Steel, Stainless Steel as well as in Malleable casting.

Our Oval Belt Fasteners are painted Auto black finish for longer life & rust prevention. We also provide them in Yellow Zinc Plating as per customer requirements and demand.

Oval Belt Fasteners Size

3/8x1 1/2" (10G), 3/8x2" (10G)
5/16x1 1/4" (10G), 1x4x1" (16G)

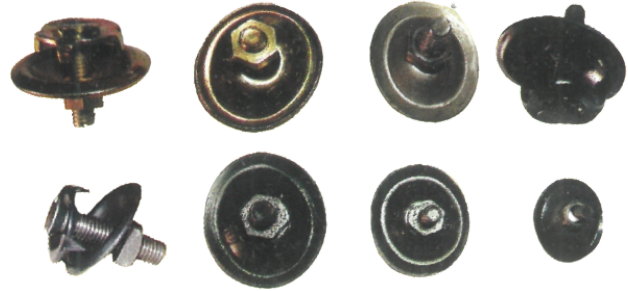

ELEVATOR BUCKET BOLTS

These Elevator Bucket Bolts are used to mount Elevator Buckets to Elevator Belts and for many other mountings. We export our Elevator Bucket Bolts in Mild steel as well as Stainless Steel as per their usage and demands. Our Elevator Bucket Bolts are painted Auto black or Zinc plated finish for longer life & rust prevention.

ELEVATOR BUCKET BOLTS Size

1/4x11", 5/16x1", 5/16x1 1/4", 3/8x1 1/2", M8, M10 & M12.



EURO BOLT AS PER DIN 15237

Our Euro Bolts are with Large Bolt Head Diameter provided with Domed washers or Flat Washer with Hex or Square nut as per customer requirements. These are used in mounting Steel Buckets & Plastic Bucket. Our Euro Bolts available in Metric Thread in M8, M10 & M12 sizes with various lengths as per customer requirements. Our Euro Bolts are painted Auto black or Zinc plated finish for longer life & rust prevention.



STANDARD GRIPWELL BELT FASTENERS

These L-Type and Knurling type fasteners are Suitable for connecting belts of a maximum thickness of 3/8(9.5mm). One of the strongest & most secure of all types of belt fasteners for leather, hair, balata, cotton & rubber belting etc. Special parallel grooves are engraved on the plates. Which improve the fasteners lasting & very effective for heavy work. Particularly suitable for joining elevator belting with no metal to metal contact around pulleys. Our Gripwell Belt Fasteners are painted Auto black finish for longer life & rust prevention. We also provide them in Zinc Plating as per customer requirements and demand.

Gripwell Belt Fasteners Size

From 2" to 12"

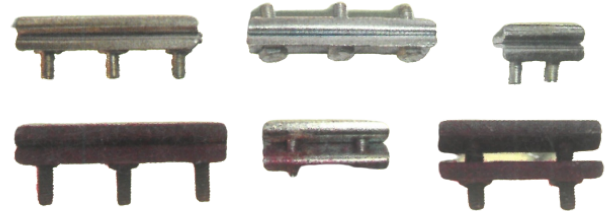

WALKER TYPE

This fastener is ideal for belts used for driving dynamos, fans, woodworking machinery etc. Also extensively used by railways for joining train lighting belts. Railways Train Lighting Belting Drive Sizes 1½" to 6"

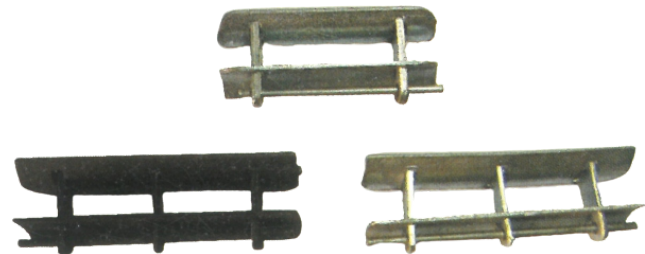

ALEGRAL TYPE

This fastener is ideal for belts used for driving dynamos, fans, woodworking machinery etc. Also extensively used by railways for joining train lighting belts. Railways Train Lighting Belting Drive Sizes 1½" to 6"

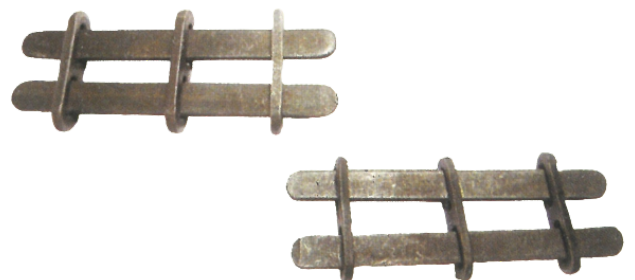

STEEL BELT LACING

We offer an excellent quality range of Steel Belt Lacings, which are manufactured from high grade quality raw materials. These are alligator type of U.S.A. Our steel belt lacing are of high durability and is designed for easy on site installation by only one person. Designed for belts from 1/32" (0.8mm) to 1/2" (12.5mm). Belt Lacing installation requires no special tools only a hammer. We manufacture our Steel Belt Lacing in CRC Steel & Stainless Steel material.

Steel Belt Lacings Size

No.1, No.7, No.15, No. 20, No.25, No.27, No.35, No.45, No.55, No.65



BELT PUNCHES

These are Designed and manufactured for Piercing Holes in all types of Belts Conveyor, Transmission, Leather, PVC Belts, Paper Wood Etc) for Belt Jointing These PUNCHES are manufactured in Alloy steels dully Hardened and Tempered. We manufacture following sizes of Belt Punches: Size 6mm, 8mm, 10mm, 12mm. Our Belt Punches are Auto Black finish or Zinc Plated for longer life & rust prevention.

Belt Punches Size

6mm, 8mm, 10mm, 12mm.



BOLT TIGHTENING KEY

These BOLT TIGHTENING KEYS are used to tighten nuts on Conveyor Belt Fasteners for Joining Conveyor Belts. These Fasteners are manufactured From Alloy steel & Hardened. We provide them in Yellow Zinc Plating Finish for longer life & rust prevention.

Bolt Tighten Key Size

No.11/2, No.2 & No.21/2, No.3.

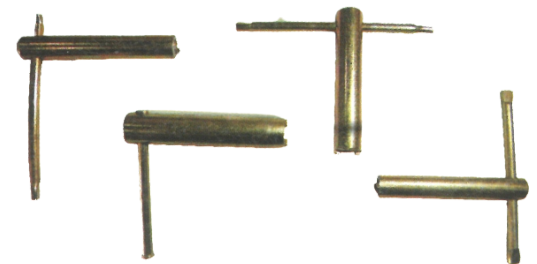

BOLT BREAKERS

These are manufactured From Alloy steel & Hardened. These BOLT BREAKERS are used to Break extra bolts left on Conveyor Belt Fasteners after Joining of Conveyor Belts. We provide them in painted Auto black finish for longer life & rust prevention. We also provide them in Yellow Zinc Plating as per customer requirements and demand.

Bolt Breakers Size

No.11/2, No.2 & No.21/2, No.3.



Grease Cups (Moto Type & Rivet Type)

These are specially designed gadgets which facilitate lubrication of the moving parts of machines for their smooth working and longevity. At present we are in the range of GREASE CUPS & OIL CUPS of different sizes as briefly detailed below.

Used for forcing the grease into bearings. Manufactured from best quality s elected steel in two different types known as **MOTO TYPE & RIVET TYPE**. Grease cup having a nipple made from same steel of cup without joint between itself known as MOTO TYPE but a separate nipple made from Hexa Steel Bar is rivetted to cup known as RIVET TYPE.

Grease Cups Size

No. 1, No. 2, No. 3, No. 4, No. 5, No. 6, No. 7, No. 8

The sizes are available in 1/4"x19" BSP Thd. & 1/8"x28" BSP Thd. & 3/8"x19" BSP Thd.



Button Bolt for Rice Huller Machine

These are used in Rice Huller Machine to fix the bottom plate. Manufactured in two qualities known as Standard and Ordinary Standard quality is manufactured from H.B. wire size 0.270" and Hexa Nut is used. But ordinary quality is manufactured from size 0.240" and square Nut is used.



Plate Bolt Fasteners (Jackson Type)

These are used where the work is heavy and places unusual strain on the belt joints, Manufactured from best quality selected steel

Size	Screw Sizes	Plate Thickness	Suitable For Belts	Suitable For Pulley
No. 0	1/4"x7/8"	16 G	2" to 5"	8" to 12" Dia
No. 1 Small	1/4"x7/8"	16 G	4" to 6"	8" to 14" Dia
No. 1 Large	1/4"x7/8"	16 G	5" to 8"	10" to 16" Dia
No. 2 Small	5/16"x1"	16 G	up to 10"	14" to 20" Dia
No. 2 Large	5/16"x1 1/8"	16 G	up to 15"	16" to 30" Dia
No. 3	3/8"x1 1x4"	14 G	up to 24"	up to 48" Dia
No. 4	3/8"x1 3/8"	14 G	up to 60"	Not less than 36" Dia
No. 5	1/2"x1 3/4"	10 G	up to 72"	From 60" Dia upward



Plate Bolts for Flour Mills

These bolts are used to fasten the grinding wheels of the vertical flour mill.

Plate Bolts for Flour Mills Size

1/2x1 3/4" , 1/2 x 2" , 1/2 x 2 1/2"



Emery Wheel Dresser Cutter

Also known as Rice Mill CONE/SHELL CUTTERS. Used for Turning, Clearing, Shaping and sharpening grinding wheels and. These tools are indispensable for reconditioning abrasive grinding wheels and proved very helpful device for removing the particals of metal which clog the grinding wheels. Manufactured from best quality selected steel. Blades are accurately machined and hardened



Size	Cutter Thickness	For Dressing Wheels	Cutter Set with Bush
No. 0.	14 G.	up to 500 MM Dia.	4 Blades 2 Washers
No. 1.	14 G.	up to 500 MM Dia.	4 Blades 2 Washers
No. 2.	14 G.	Larger Size	6 Blades 2 Washers

Worm Blades with Hexa Nuts

Used in paddy Drier plants Manufactured from Best Quality selected steel.

Size	Plate Thickness	Bolt Size
6"	10 G.	3/8" x 3 1/8"
7"	10 G.	3/8" x 3 1/8"
8"	8 G.	1/2" x 3 1/8"



Oil Cups

Manufactured in two types commercially known as spring LID & Elblow OIL CUPS. These are fitted such on horizontal and vertical surface of machines to ensure continuously oiling into moving components of the same. The flow of oil can be increased by removing one or more strings of woolen wick.

Size	B.S.P.	B.S.W.
1/2" Dia	1/8"	3/8"
5/8" Dia	1/8"	3/8"
3/4" Dia	1/8" & 1/4"	3/8" & 1/2"
7/8" Dia	1/8" & 1/4"	3/8" & 1/2"
1" Dia	1/8" & 1/4"	3/8" & 1/2"
1 1/4" Dia	1/4"	1/2"
1 1/2" Dia	1/4"	1/2"
2" Dia	1/4"	1/2"



Bright Seamless Elevator Buckets

We supply all types of elevator buckets in M.S., S.S. Plastic PVC, Nylon Buckets & Plastic Buckets in Shovel Type.

4x3 3/4x2 3/4	7x4 3/4x3 1/2	12x6x5
5x4x3 1/4	8x4x3 1/4	12x8x5
5x4 3/4x3 1/2	8x5 1/4x4 1/2	14x7x5
6x4x3 1/2	9x6x5	
6x4 3/4x3 1/2	10x6x5	



Note : Any other special sizes can be manufactured on confirmed order. Rates Stainless Steel Elevator Buckets will be offered on application.



Notes....

A series of horizontal dashed lines for taking notes.

BSK OVERSEAS INC.

104-A, Sant Avenue, G.T.Road, Amritsar-143001(Pb), India

Phone: +91(843)700-2153

Email: info@bskoverseas.com

www.bskoverseas.com

